

Medical Shower & Tap

Legionella & Bacterial Control

Product & Validation Guide



Contents

Introduction

Fileder in Partnership _____	3
Pentair Medical Shower & Tap Overview _____	4

The Product and Technology

Sterilised Shower & Tap Range _____	8
Product Features & Benefits _____	10
Hollow Fibre Technology _____	12
Packaging & Labelling _____	14
Shower Filter in use - Air-Locking _____	16
Tap Filter in use - Adaptor System _____	17
Case Studies _____	18

Sterilised Range Validation Guide

Sterilised Range Introduction _____	24
Microbiological Tests _____	25
• <i>Pseudomonas diminuta</i>	
• <i>Pseudomonas aeruginosa</i>	
• <i>Legionella pneumophila</i>	
• <i>Fusarium solani</i>	
Clinical Tests _____	29
• Antimicrobial Efficiency Tests	
• Chemical Resistance	
• Flow Rate & Pressure Test	

Appendices

Management Summaries _____	35
Manufacturer's Datasheet _____	45
Certification _____	47
Installation Instructions _____	50

Fileder in Partnership

Fileder Filter Systems and Pentair have worked in partnership for over 40 years, supplying liquid filtration and water treatment products to many market sectors.

Outstanding service from a supplier of highly engineered, tested and certified products is a combination that has worked successfully for a number of years.



Fileder is one of the largest independent filtration suppliers in the UK, stocking over £5m of filtration and water treatment products. The global brands included in the Fileder portfolio are PENTAIR, SPECTRUM and AXEON. Access to this wide range of products enables Fileder to recommend and supply system solutions appropriate for all liquid filtration and water treatment requirements.



Pentair manufactured their first product in 1966 and continued growth since has led them to global annual revenues exceeding \$5bn in 2018, employing 27,600 people worldwide. Key factors influencing the success of Pentair has been product design, intensive product testing and production quality control.

ISO 13485 accreditation for manufacturing.



Pentair Medical Shower and Tap Overview

Introduction

Pentair Medical Shower and Tap Filters utilise the latest developments in filtration technology by incorporating polyethersulfone hollow fibre membranes as the filtration media. These filters are commonly used in hospitals, care homes and accommodation to control *Legionella*, *Pseudomonas* and other bacteria by removing them from the water at the point-of-use (POU). Validated according to ASTM F838-05 for 92 days for the range of products. This validation included independent laboratory challenges with *Legionella pneumophila*, *Pseudomonas diminuta* and *Klebsiella terrigena*, with greater than Log7 reduction achieved for all bacteria and *Aspergillus fumigatus* with Log4 reduction of fungi.

Hollow fibre membranes provide a simple yet effective method of purifying water, using non-chemical physical separation to remove microbiological contaminants from the incoming water source, negating the requirement for additional pre-filtration at the POU. Polyethersulfone is formed into small hollow tubes with billions of microscopic pores in the wall of the tube. These pores have a maximum size of 0.2µm and are designed to allow the passage of water across the membrane media. The uniformity of the pores in the walls is controlled by the strict manufacturing processes applied, resulting in a membrane that will physically exclude the movement of microbiological contaminants such as bacteria, cysts, fungi and some viruses; allowing clean, safe water to be used.

History

Hollow fibre membranes are thought to have been first developed as early as 1930. However, it was not until the 1960s when the technology was truly made available for commercial use, that it was utilised as a method of treating wastewater and in the processes of desalination, blood transfusion and cell culture. Over the last 50 years, the technology has seen many improvements in both the manufacturing processes and in the performance of hollow fibre membranes, allowing the technology to be used in affordable, personal-use, water purification products such as Pentair Medical Shower and Tap Filters.



Market Penetration

Since the initial product development and market introduction in 2007, the sales of the Pentair Medical Shower and Tap Filters have steadily increased, as distributors and end-users alike have discovered the dependability and quality assurance of the product range. Producing over 1,000,000 units a year for use across a number of countries, the Pentair Medical Shower and Tap Filter products continue to provide effective point-of-use bacterial protection.

Pentair Medical Shower and Tap Filters are being sold directly to many countries.

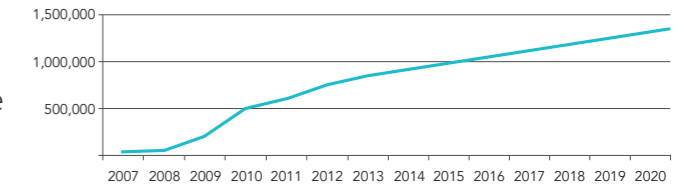

Certification

Tested and approved by several internationally recognised bodies, the Pentair Medical Shower and Tap filters are a trusted and reliable solution, providing effective patient protection against waterborne pathogens. Bringing peace of mind to both installers and patients these filters have passed the rigorous testing conducted by certification bodies such as WRAS, DVGW and Kiwa.





The Product & Technology

- Sterilised Shower & Tap Range
- Product Features & Benefits
- Hollow Fibre Technology
- Product Construction
- Packaging & Labelling
- Shower Filter in use - Air-Locking
- Tap Filter in use - Adaptor System
- Case Studies

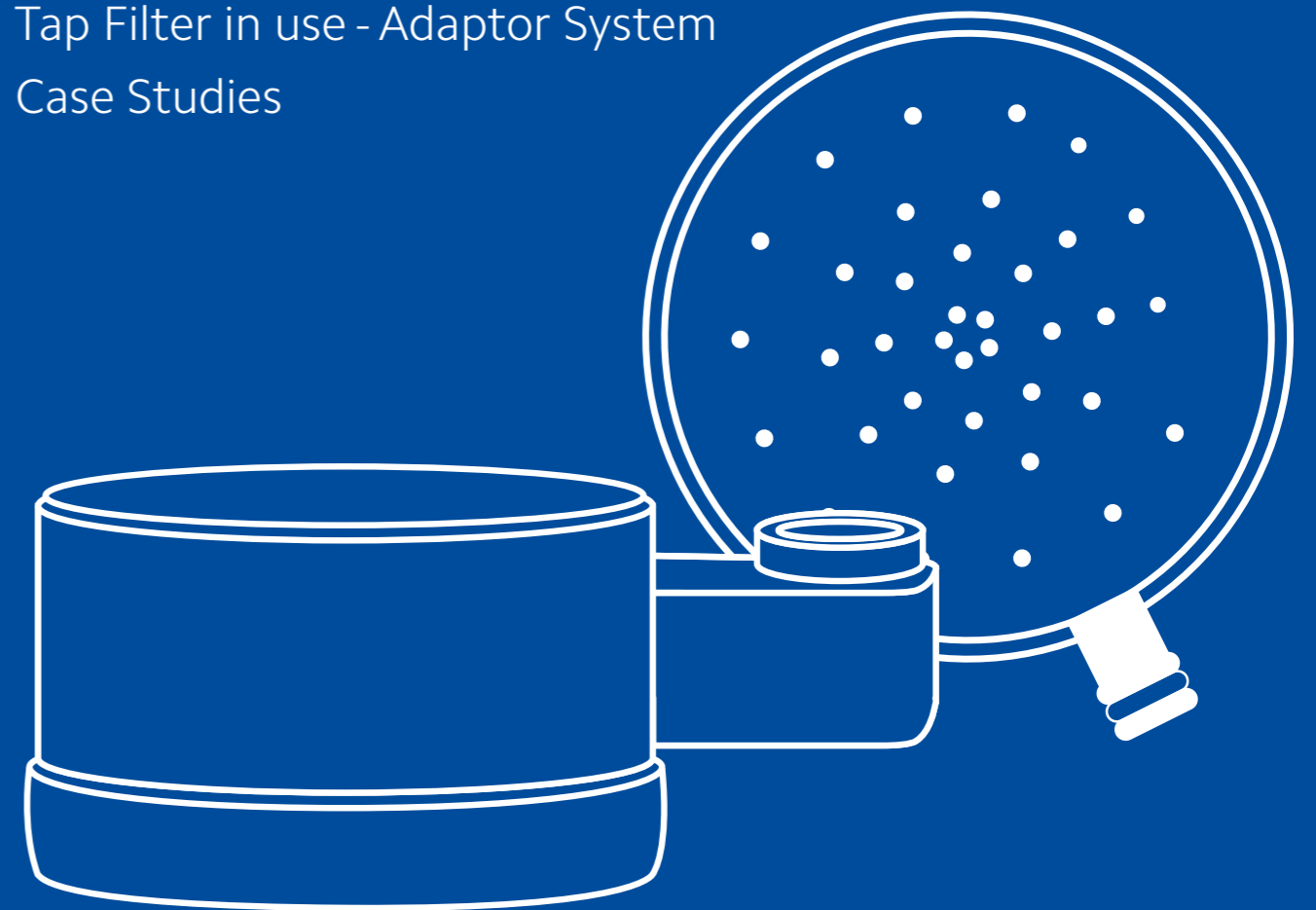

Sterilised Shower & Tap Range

Sterilised Range

The Pentair Medical Water Filters deliver efficient and cost-effective membrane filtration to provide clean and safe water.

Pentair's Sterilised range of Medical Shower & Tap Filters from the X-Flow range of hollow fibre products is provided in gamma irradiated packaging for sterility.

Common bacteria such as *Pseudomonas* is transmitted to the filter from people's hands during installation, and can multiply at high rates in the right conditions, which promotes the possibility of the external bacteria being washed into the flow stream and making contact with the patients, residents or staff. The active ingredient used in the spray cap minimises this bacteria growth.

Widely used in hospital, clinical and accommodation settings, they ensure patient, resident and staff safety. The Sterilised range, including the Shower Filter and Tap Filter, have proven to be an excellent choice to ensure water safety in high-risk areas, such as haematology, oncology, burn centres, critical and intensive care units (ICU), and operating theatres. Medium-risk areas, such as kitchens, changing rooms, residential accommodation and patients' rooms have also benefited from clean, safe water with their use.

To accompany the tap range, a choice of filter-to-tap adaptors is available, covering the majority of sizes of medical taps, including M24 male, M18 male, 1/2" male, 1/2" female and a universal fitting. The range also includes a flow restrictor to reduce water wastage and control flow rates in higher pressure applications.



MTFW-SLSS

Sterilised Tap Filter Starter Set



MSF-SLSS

Sterilised Shower Filter Starter Set



MSF-SCRC

Sterilised Shower Filter Replacement

Tap Adaptors

Taps Fitted	Tap Thread Size	Adaptor Code	Description
Horne	M24	MTF-TA24-S/S	The majority of medical tap manufacturers now supply taps with an M24 size diffuser. When the diffuser is removed the cavity is filled with the Filerder tap adaptor which includes an ISO metric type thread (M24) and O-rings for a watertight seal.
Armitage Shanks - Contour & Markwik			
Delabie			
Twyford			
Grohe			
Bristan			
Kohler Mira - Rada ACU	M18	MTF-TA18-S/S	This tap has a built-in sensor that allows water flow with a wave of the hand. Filerder designed this adaptor to be longer to avoid sensor activation by the filter. This tap also has a narrower thread (M18).
Armitage Shanks - Markwik	M21.5	MTF-TA215-S/S	Part of the newer Markwik or Armitage Shanks bioguard outlets
Armitage Shanks	1/2" Female	MTF-TA1/2M	Some manufacturers include a 1/2" internal thread in their range for the diffuser, typically for the older models.
Internal Thread	1/2" Female	MTF-TA1/2M	Some manufacturers include a 1/2" internal thread in their range for the diffuser, typically for the older models.
External Thread	1/2" Male	MTF-TA1/2F	A few manufacturers have a 1/2" external thread to include an anti-splash device, such as Markwik wall mixer range (eg S8200).
Various	None	MTF-TAU	Due to the wide range of taps available, the Universal tap adaptor covers for almost all tap sizes. Please advise Filerder of your requirements.



MTF-TA24-S/S

24mm male to 22mm



MTF-TA21.5-S/S

21.5mm male to 22mm



MTF-TA18-S/S

18mm male to 22mm



MTF-TA16-S/S

16mm male to 22mm



MTF-TAU

Universal tap adaptor



MTF-TA1/2M

1/2" male to M22



MTF-TA1/2F

1/2" female to M22



MTF-FR

Flow regulator

Product Features and Benefits

Delivering water that is safe to use from an easy-to-use system requires a number of features, some of which are highlighted below.

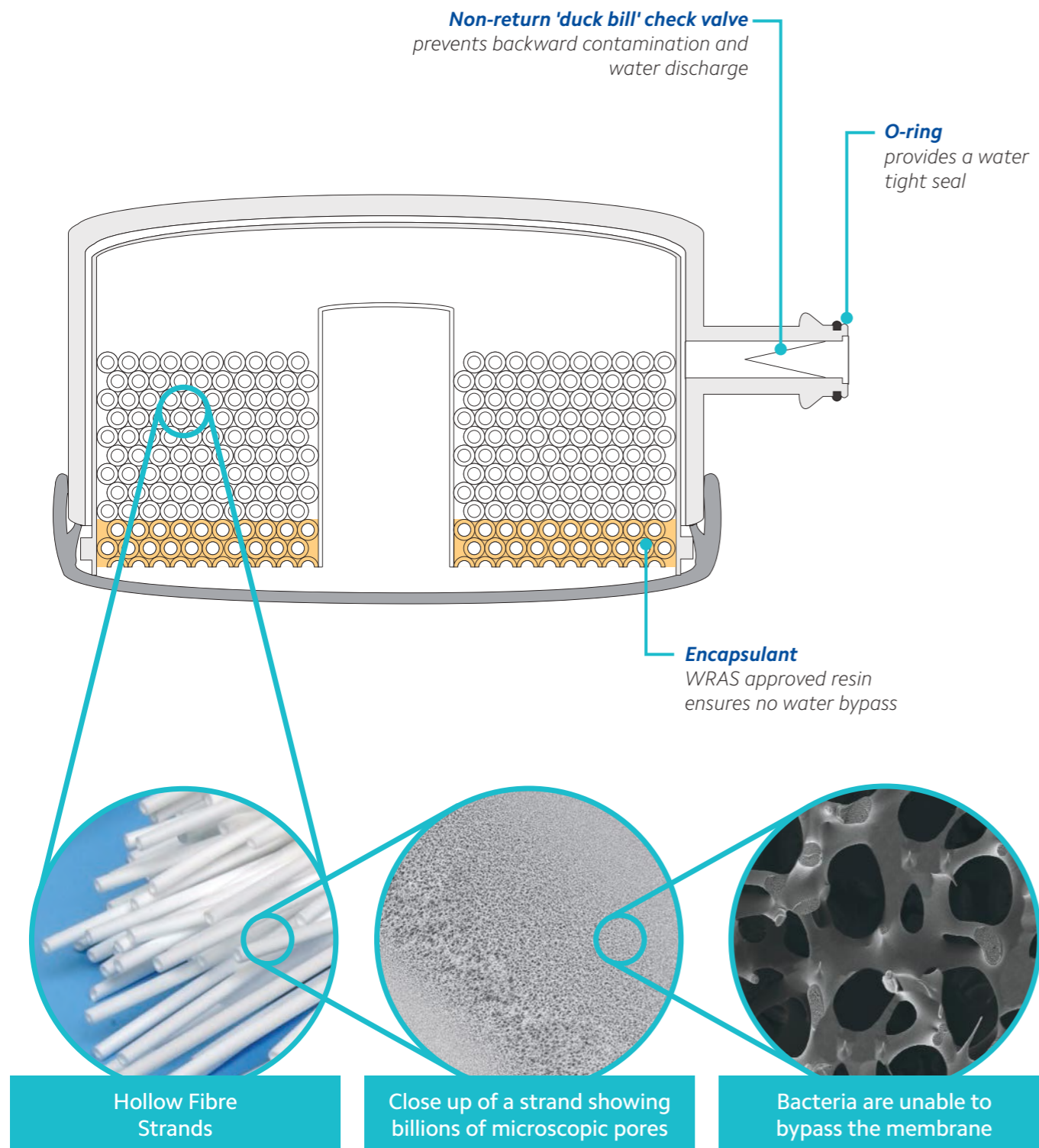

Performance

- 0.2 absolute micron rating – validated results of:
 - >log 7 reduction of bacteria
 - >log 4 reduction of fungi
- No air-locking of shower range – can be used at low height
- Validated service life of 92 days:
 - lower labour and filter replacement costs
 - treble the service life of the market leader
- Antimicrobial outlet surface – reduced bacteria growth on filter surface
- \geq Log 6 *Pseudomonas* retention for 6 months



Technology

- Special key – prevents common issue of unwanted filter removal
- Low waste – only the filter is replaced, handle can be re-used
- Ergonomic design – tap movement capability
- High contaminant holding – billions of pores in each hollow fibre strand
- Sampling – filter can be removed and reattached during sampling



Approved

- WRAS approved product, approval number - 2205057
- Independently tested validation guide – eliminates product bias
- Full traceability - includes barcoded tracking and tracing labels



Hollow Fibre Technology



The latest innovations in manufacturing processes enable Pentair to form the polyethersulfone (PES) active ingredient into structural hollow fibres. This is a continuation of filtration technology development from the thin layer of PES incorporated into flat sheet membranes. By utilising only the PES membrane media without a substrate, more of this active filtration media is used in filtration products, offering better performance when compared with flat sheet technology.

Hollow fibre technology is widely used for drinking water, healthcare, community swimming pools and industrial process water due to its consistent performance and reliability. X-Flow hollow fibre membrane technology provides 5% of the world's drinking water meaning it is tried, tested and trusted globally.

The PES media is typically formed into 1.2mm diameter tubes to create a solid hydrophilic porous structure that allows the flow of water but not of unwanted contaminants. The pore size is important and is determined by the individual application requirements. Wider pore sizes are used to remove a broad size range of particulate as part of a pre-filtration process requiring very high flow, whereas tight pore sizes are set for more specific contaminant in lower flow applications. For the Pentair Medical Shower and Tap products, flow of water through the membrane at low pressure and the removal of bacteria are the key factors influencing the setting of the maximum pore size to 0.2µm (micron). At this micron rating, the hollow fibre media prevents bacteria from passing through. This has been independently tested at Log7 reduction i.e. 99.99999% removal rate of live bacteria.

Customers can trust X-Flow, one of the leaders in membrane technology to control process parameters to produce the highest quality products each time. Products are tested for membrane integrity before packaging and delivery to the customer, providing total peace of mind.

Media Quantity

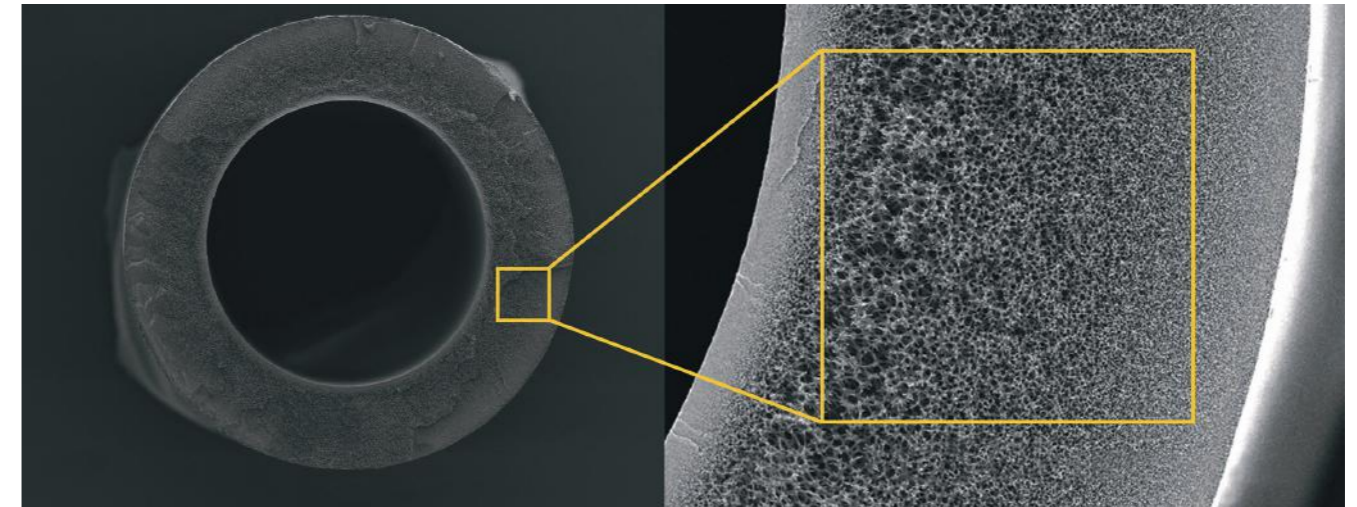

Hollow fibre cross section - 200µm PES wall thickness

The process of manufacturing the traditional flat sheet membrane is to use a media (often polyolefin) substrate, applying an adhesive and then applying the active polyethersulfone ingredient in a thin layer on top. By utilising only the active ingredient as the media, more active ingredient is incorporated in the hollow fibre technology (X-Flow hollow fibre wall thickness of 200µm in the fibres compared with typically 50-100µm in flat sheet membranes). This higher volume of media means higher dirt holding capacity and more area for water to freely flow through the media. When lower than required flow rate occurs, the user's frustration may even lead to them removing the filter to increase the flow rate which would negate the purpose of using the filter.

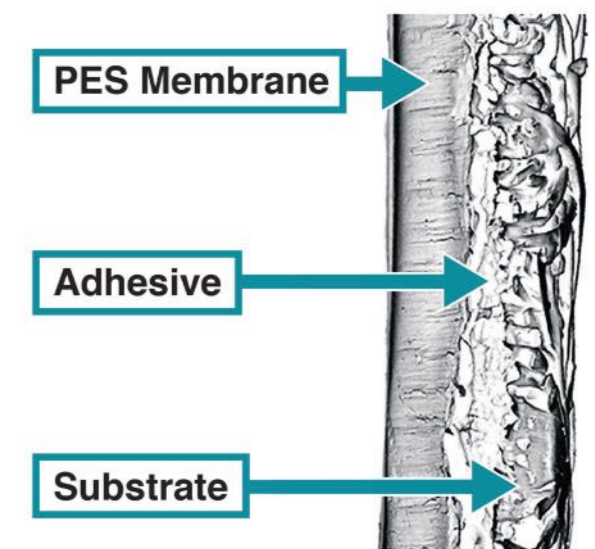

Flat sheet cross section - 50-100µm PES thickness

Flow Pattern

Temperature and pressure both have an effect on the performance and characteristics of a hollow fibre membrane. Different hollow fibre products flow in different ways; some hollow fibre membranes flow from inside-to-out to achieve the reduction of microbiological contaminants. This flow pattern is limited by its pressure resistance and as with other technologies, such as pleated membranes, excess pressure and temperature can cause the pores in the media to open, reducing the overall retention rates of the product.

Pentair Medical Water Filters employ an outside-to-in flow pattern, significantly increasing the pressure resistance of the hollow fibre media. This particular flow pattern has a positive effect on the pore size of the membrane, ensuring that the product has an extremely stable cut-off point, removing contaminants greater than 0.2µm.

Packaging & Labelling

Labelling of critical products is of paramount importance to keep control of an application's various parameters that, if left unchecked, can lead to errors with potentially damaging results. Controlling these parameters involves clear identification procedures for the chosen solution. Each Pentair Medical Shower and Tap Filter is labelled on the packaging with a label similar to the below, which indicates all that is required to control the identification, installation and tracking information of the product in use and in storage.

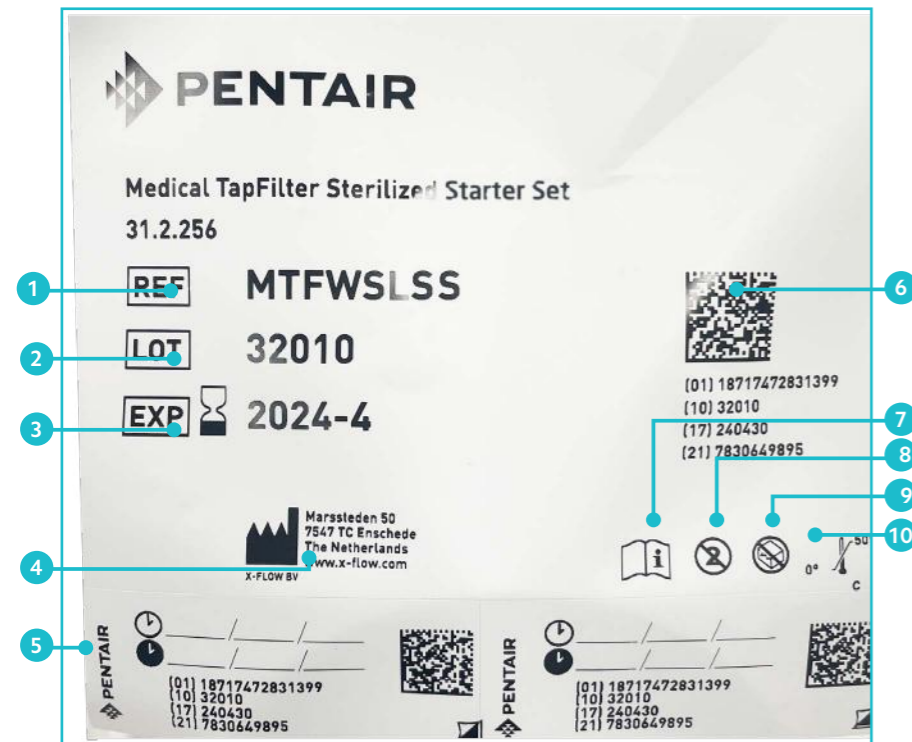

- 1 Product number
- 2 Tracking & tracing
- 3 Expiry date
- 4 Manufacturer's contact information
- 5 Tracking labels
- 6 QR Code
- 7 Refer to manual
- 8 Single use product
- 9 Handle with care
- 10 Storage conditions



Tracking Labels System

To ensure filter change out within the 92-day validation period, each filter comes complete with identification stickers (tracking labels). Keeping track of when to change and the location of the filter is easier with the inclusion of these two identical labels. One is placed on the product when it is installed, the other is for the fitter to keep on their records sheet. Both labels have the date of installation and due date for change. The fitter can then monitor the filter change routine to suit and easily locate the filters when the change is due.

- 1 Apply the tracking label to the product

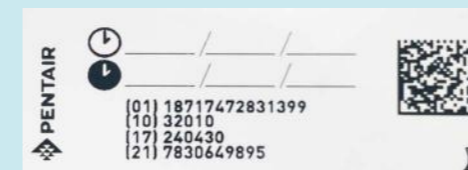

- 2 Apply matching tracking label to fitter's records

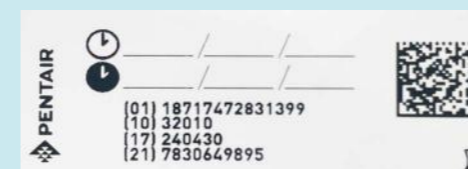

Shower Filter in Use - Air Locking

Feedback received from users of the market leading flat sheet membrane POU Shower Filters, stated issues of air-locking occurred when the shower head was lowered, for instance to shower a child. This caused inconvenience for the nurse and the patient and, since the only way to resolve this was to replace the filter immediately, the issue wasted time and money.

Following extensive research the Medical Shower Filters have been proved to prevent the possibility of air-locking. This means the Medical Shower Filter is effective in a wider variety of showering applications without issue or additional costs.

Knowing that there is no air-locking risk, combined with the extensive surface areas of the hollow fibre strands, means the Medical Shower Filters have been used at pressures as low as 1 bar (14.5 psi).

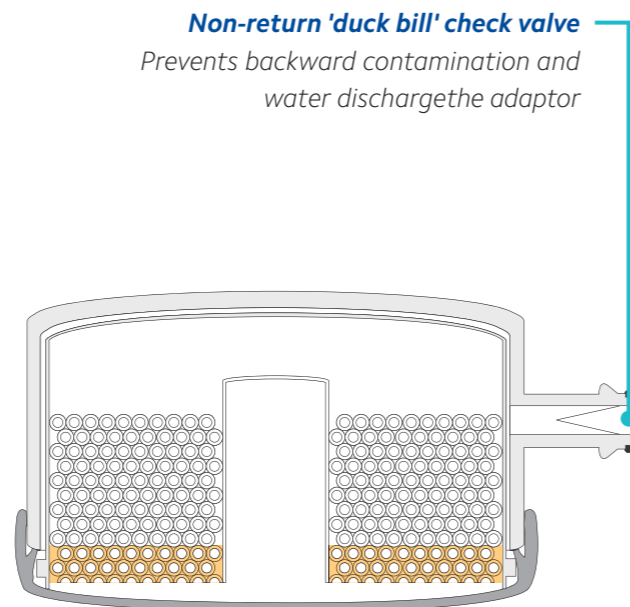

Tap Filter in Use - Adaptor System

Using the best filter in the world would offer only limited success if any water bypassed the tap-to-filter adaptor. This connection is critical for healthcare taps, as a sub-standard adaptor will enable water bypass, encouraging bacteria growth in the area.

Filerder overcame this common issue by designing adaptors specifically to seal the filter to the wide variety of tap manufacturers' products and created a Medical Tap Filter system. The adaptor replaces the diffuser (supplied with each tap) and is made from durable 316L stainless steel, which can be autoclaved for sterility and re-used after the O-rings are replaced.

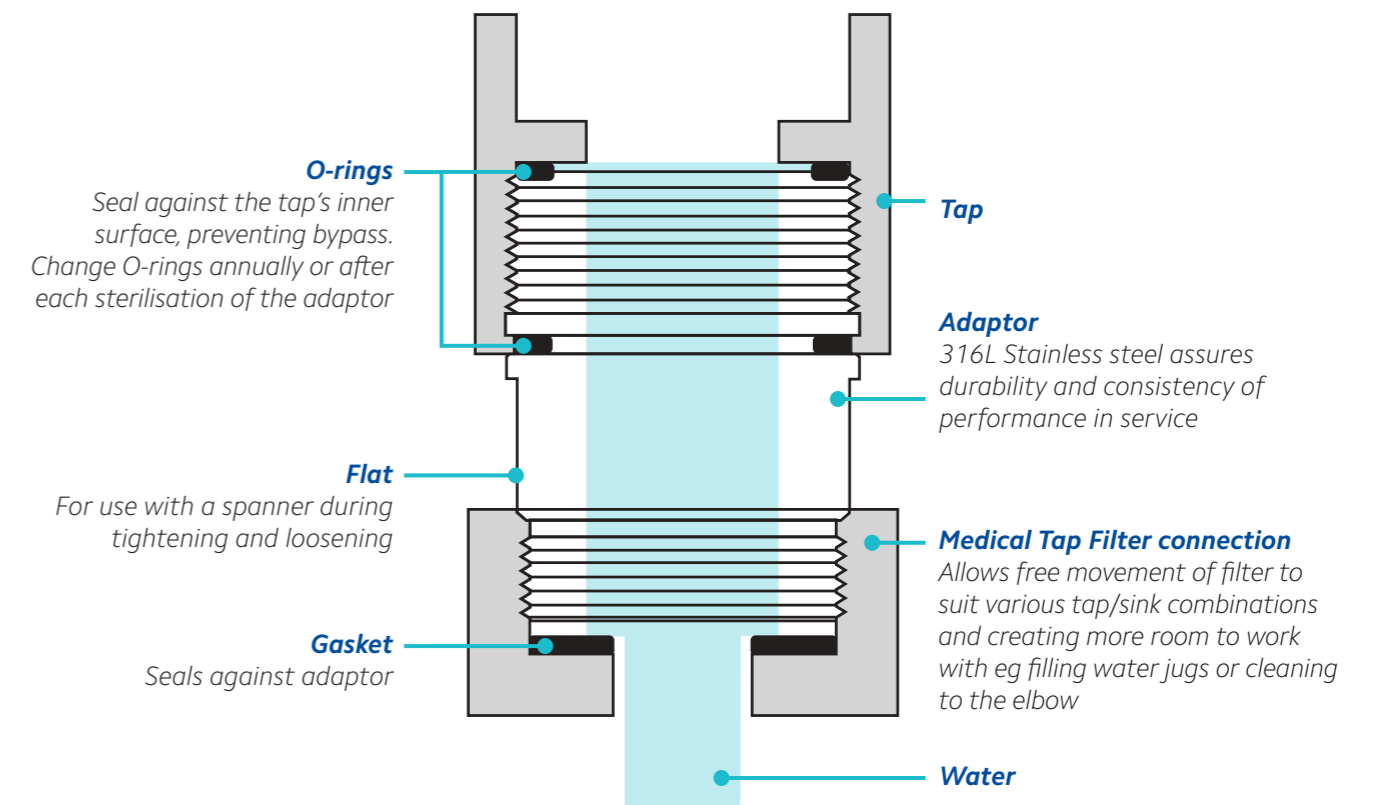

Taps successfully fitted to:

- Armitage Shanks
- Delabie
- Horne
- Grohe
- Twyford
- Kohler Mira
- Bristan
- Plus many more

See page 9 for further details.





Western Sussex Hospitals

Worthing Hospital is part of the Western Sussex Hospitals NHS Trust. Located near Brighton, Worthing Hospital provides a full range of general acute services, including A&E, Surgical Care Unit, Outpatients and Intensive Therapy Unit.

Paul Kingsley-Holmes, Water Engineer, contacted Filerder to explain about some issues they were having with the current filter; sometimes being removed by staff, to create improved flow of water. Without the filters in place, there was the increased risk of infection from waterborne microorganisms. There was also concern about using the existing filter for its 31-day validation period in lower pressure areas as the flow rate was lower than wanted.

Filerder were invited to conduct a site survey to investigate this feedback and specify an appropriate solution. By supplying the Pentair Medical Tap Filter, issues of low flow were overcome. Also, the filters were no longer removed by users and only by the authorised engineer, when the full validation period was over. The filters were fitted to the taps using the 316L stainless steel adaptors, designed specifically by Filerder to ensure a leak-free result with additional benefit of being able to be sterilised by autoclave on site at the hospital.

Paul Kingsley-Holmes said, "The Pentair Medical Tap filters outperformed the existing filters with over double the service life, which is a significant cost saving. Unwanted filter removal has stopped, there are no signs of leaks, and we now achieve the full validation period in the low pressure areas. The Pentair Medical Tap Filters are the right choice for general bacterial control at the point-of-use."

“ The Pentair Medical Tap filters outperformed the existing filters with over double the service life, which is a significant cost saving. Unwanted filter removal has stopped, there are no signs of leaks, and we now achieve the full validation period in the low pressure areas. The Pentair Medical Tap Filters are the right choice for general bacterial control at the point-of-use. ”

Paul Kingsley-Holmes
Water Engineer



St. Richard's Hospital

St. Richard's hospital is part of the Western Sussex Hospitals NHS Trust. Providing a full range of general acute services including A&E, Maternity, Outpatients, day surgery and intensive care.

Ralph Woolgar, Estates Workshop Manager, contacted Filerder during an investigation into the effectiveness of their *Legionella* protection regime. He explained he had a number of issues including the current filter being removed by staff, patients and the general public, making them ineffective and also he was struggling with the low pressure applications to get a decent flow rate of water over the length of the existing filter's 31-day validation period.

Filerder overcame the issues being experienced by supplying the Pentair Sterile Medical Shower and Tap filters. The Tap filter locks into a fitting and is not so easy to remove than others on the market (detachment point is not easily visible to the user). The Tap filter also has an adaptor made from 316L stainless steel, which fitted to their taps and was described as a far better practical solution as it is incredibly robust, leak-free and can be sterilised in an autoclave which Infection Control liked too.

For the lower pressure applications, the Pentair Medical Tap filter outperformed the existing filter with lower pressure drop across the filter and higher contaminant holding. Filerder also explained there is a 'duck-bill' valve that can be removed from the filters to further increase flow if required.

Ralph Woolgar said, "The Pentair Medical Shower and Tap filters are the right solution for *Legionella* and general bacterial protection at the point-of-use. The use of engineered tap adaptors and the ergonomic design of the filters have brought peace of mind and stopped unwanted filter removal. In our low pressure areas we also now achieve the full validation period."

“ The Pentair Medical Shower and Tap filters are the right solution for *Legionella* and general bacterial protection at the point-of-use. The use of engineered tap adaptors and the ergonomic design of the filters have brought peace of mind and stopped unwanted filter removal. In our low pressure areas we also now achieve the full validation period. ”

Ralph Woolgar
Estates Workshop Manager



Sterilised Range Validation Guide

- Introduction
- Microbiological Tests
- Clinical Tests
- Antimicrobial Efficiency Tests
- Chemical Resistance
- Flow Rate and Pressure Test



Sterilised Range Introduction

From the purification plant to the actual point-of-use, water passes a variety of piping and distribution systems. Although initially the microbial load at the outlet of the plant is often relatively small, a high microbial count can be found at the end of this chain. Many of these microorganisms are harmless, but opportunistic pathogens like *Pseudomonas aeruginosa*, *Legionella pneumophila* and several fungi can be found as well. Microorganisms can accumulate on surfaces and grow to form a so-called biofilm. These biofilms are very difficult to remove by chemical or heat shock treatments and regularly release microorganisms in the water for further colonisation. From the water phase opportunistic pathogens can reach humans via drinking, inhalation of aerosols and bathing. This, in turn, can lead to infections and diseases like Legionellosis.

Pentair Medical Water Filters contain capillary microfiltration membranes with a pore size of 0.2 micron, which effectively retain bacteria and fungi. While water molecules pass through the porous wall of these hollow fibre membranes, the pores retain microorganisms and other particular contaminants. The Pentair Medical Water Filters provide easy and reliable protection at the last possible moment before patient contact. The Medical Water Filters are available in two configurations, as a Shower Filter and as a Tap Filter.

This validation guide summarises tests that have been performed for validation and qualification of the Pentair Medical Water Filters. All tests have been performed with regular off-the-shelf sterilised products. Sterilisation of the product is done by gamma irradiation treatment with a minimum dose of 25 kGy.



Microbiological Tests

1.1 Retention of *Pseudomonas diminuta* (ASTM F838-05)

Membranes retain all particles that are larger than their pores and allow passage of water and smaller particles. Thus retention of a small bacterium should be evaluated as a worst case scenario. Testing with the small bacterium *Pseudomonas diminuta* was performed by Vitens Laboratory, the Netherlands, an ISO 17025 accredited lab. The tests were performed under test conditions specified in the ASTM F838-05 protocol for the validation of 0.2 µm sterilising grade filters.

1.1.1 Test description

Membranes were challenged with a high microbial load of at least 10⁷ bacteria per cm² effective filtration membrane area. The bacteria were suspended in a pressure vessel and passed through the filters. Influent and different effluent samples were collected and analysed at Vitens Laboratory. The samples were plated and incubated for 48 hours at 30°C, after which an identification and enumeration of *Pseudomonas diminuta* was performed. The test was performed in triplo.

1.1.2 Test results

In Table 1 the enumeration results of the influent and effluent samples taken during this test are summarised. The influent samples all meet the criterion of 1 x 10⁷ CFU/cm². The effluent samples are taken from a mixture of the first 5L of effluent water and of the filtrate after 5L. In both types of effluent samples no *P. Diminuta* was detected.

Table 1: Retention of *Pseudomonas diminuta* by Pentair Medical Water Filters performed in triplo according to the ASTM F838-05 protocol.

Filter	Influent			Effluent			
	Total CFU load	CFU/cm ²	CFU/L	After 5L suspension filtrated	Log reduction	Mixed sample from 5L	Log reduction
1	4 x 10 ¹⁰	3.33 x 10 ⁷	8 x 10 ⁹	<100	>7.2	<100	>7.2
2	4 x 10 ¹⁰	3.33 x 10 ⁷	8 x 10 ⁹	<100	>7.2	<100	>7.2
3	3 x 10 ¹⁰	2.5 x 10 ⁷	6 x 10 ⁹	<100	>7.2	<100	>7.2

1.1.3 Conclusion

No bacteria were detected in effluent samples resulting in a Log reduction >7.2 for all the samples. This meets the international standard for microbial water purifiers retention of Log 6.

1.2 Microbial retention over the lifetime of the product

As the ASTM F838-05 test only tests at one point in time it is important to see what the microbial retention of the product is over its defined life time. The tests below are conducted on different microorganisms for a period of 92 days to show the product retains the same microbial retention over its total lifetime.

1.2.1 Test description

To test the microbial retention over the lifetime of the filter a dedicated setup was developed and tests were performed based on the NSF protocol P231 protocol for microbial water purifiers. Membranes were challenged with a high microbial load three times per week over a period over 92 days, the indicated lifetime of the product. Effluent microbial concentrations were measured and compared to influent concentration to determine the log reduction. Tests were performed on the reference bacterium *Klebsiella terrigena*, the clinically relevant *Legionella pneumophila* and *Pseudomonas aeruginosa* and the opportunistic fungi *Aspergillus fumigatus* and *Fusarium solani*.

Table 2: Log reduction values for the retention of *Pseudomonas aeruginosa*

Filter cartridge	Sample 1	Sample 2	Sample 3
	Log retention in effluent		
Start of the test	>6.4	>6.4	>6.4
After 1 day	>6.4	>6.4	>6.4
After 3 days	>6.4	>6.4	>6.4
After 1 week	>7.3	>7.3	>7.3
After 1 week and 1 day	>6.9	>6.9	>6.9
After 1 week and 3 days	>7.0	>7.0	>7.0
After 2 weeks	>6.0	>6.0	>6.0
After 2 weeks and 1 day	>7.4	>7.4	>7.4
After 2 weeks and 3 days	>7.0	>7.0	>7.0
After 3 weeks	>6.8	>6.8	>6.8
After 3 weeks and 1 day	>7.3	>7.3	>7.3
After 3 weeks and 3 days	>7.1	>7.1	>7.1
After 4 weeks	>6.8	>6.8	>6.8
After 4 weeks and 1 day	>6.7	>6.7	>6.7
After 4 weeks and 3 days	>6.8	>6.8	>6.8
After 5 weeks	>8.1	>8.1	>8.1
After 5 week and 1 day	>8.1	>8.1	>8.1
After 5 week and 3 days	>7.8	>7.8	>7.8
After 6 weeks	>6.1	>6.1	>6.1
After 6 weeks and 1 day	>6.1	>6.1	>6.1
After 6 weeks and 3 days	>6.3	>6.3	>6.3
After 7 weeks	>6.7	>6.7	>6.7
After 7 weeks and 1 day	>6.2	>6.2	>6.2
After 7 weeks and 3 days	>7.0	>7.0	>7.0
After 3 months	>7.3	>7.3	>7.3

Table 3: Log reduction values for the retention of *Legionella pneumophila*

Filter Cartridge	Sample 1	Sample 2	Sample 3
	Log retention in effluent		
Start of the test	>6.8	>6.8	>6.8
After 4 days	>7.0	>7.0	>7.0
After 5 days	>7.5	>7.5	>7.5
After 1 week	>7.6	>7.6	>7.6
After 1 week and 4 days	>8.6	>8.6	>8.6
After 1 week and 5 days	>7.5	>7.5	>7.5
After 2 weeks	* o.D.	o.D.	o.D.
After 2 weeks and 4 days	>8.5	>8.5	>8.5
After 2 weeks and 5 days	>7.2	>7.2	>7.2
After 3 weeks	>7.1	>7.1	>7.1
After 3 weeks and 4 days	>7.0	>7.0	>7.0
After 3 weeks and 5 days	>6.9	>6.9	>6.9
After 4 weeks	>7.0	>7.0	>7.0
After 4 weeks and 4 days	>7.1	>7.1	>7.1
After 4 weeks and 5 days	>7.1	>7.1	>7.1
After 5 weeks	>7.1	>7.1	>7.1
After 5 weeks and 4 days	>6.9	>6.9	>6.9
After 4 weeks and 5 days	>7.0	>7.0	>7.0
After 6 weeks	>7.1	>7.1	>7.1
After 6 weeks and 4 days	>7.0	>7.0	>7.0
After 6 weeks and 5 days	>6.4	>6.4	>6.4
After 7 weeks	>7.2	>7.2	>7.2
After 7 weeks and 4 days	>7.2	>7.2	>7.2
After 7 weeks and 5 days	>7.4	>7.4	>7.4
After 8 weeks	>7.3	>7.3	>7.3
After 11 weeks	>7.1	>7.1	>7.1

* No data due to an error in sample acquisition

Clinical Tests

Table 4: Log reduction values for the retention of *Fusarium Solani*

Filter cartridge	Log retention from <i>Fusarium solani</i>		
	Sample 1	Sample 2	Sample 3
Start of the test	>3.9	>3.9	>3.9
After 1 day	>3.7	>3.7	>3.7
After 3 days	>3.7	>3.7	>3.7
After 1 week	>4.0	>4.0	>4.0
After 1 week and 1 day	>4.1	>4.1	>4.1
After 1 week and 3 days	>4.0	>4.0	>4.0
After 2 weeks	>4.0	>4.0	>4.0
After 2 weeks and 1 day	>4.2	>4.2	>4.2
After 2 weeks and 3 days	>4.0	>4.0	>4.0
After 3 weeks	>4.0	>4.0	>4.0
After 3 weeks and 1 day	>4.2	>4.2	>4.2
After 3 weeks and 3 days	>4.2	>4.2	>4.2
After 4 weeks	>4.2	>4.2	>4.2
After 4 weeks and 1 day	>4.2	>4.2	>4.2
After 4 weeks and 3 days	>4.3	>4.3	>4.3
After 5 weeks	>4.3	>4.3	>4.3
After 5 weeks and 1 day	>4.4	>4.4	>4.4
After 5 weeks and 3 days	>3.7	>3.7	>3.7
After 6 weeks	>4.1	>4.1	>4.1
After 6 weeks and 1 day	>4.1	>4.1	>4.1
After 6 weeks and 3 days	>4.2	>4.2	>4.2
After 7 weeks	>3.7	>3.7	>3.7
After 7 weeks and 1 day	>4.1	>4.1	>4.1
After 7 weeks and 3 days	>3.8	>3.8	>3.8
After 3 months	>4.1	>4.1	>4.1

1.2.2 Test results

The log reduction for each microorganism is shown over the duration of the test, 92 days. Results are shown for the samples taken at the start of the test and for every week. Extended results for all of these retention tests can be found in the management summaries issued by Vitens Laboratory. These are added as appendices to this validation guide.

1.2.3 Conclusion

For both *Klebsiella terrigena*, *Legionella pneumophila* and *Pseudomonas aeruginosa* a reduction of more than Log 6 was obtained for the complete 92 days, compliant with international standards. Furthermore, no *Aspergillus fumigatus* and *Fusarium solani* was detected in the effluent samples resulting in a minimal retention of Log >3.9.

The Management Summaries of the microbiological tests issued by Vitens Laboratory are added in Appendices, pages 35-44.

In order to evaluate the Pentair Medical Water Filters for their actual use, clinical tests were performed in a hospital with an increased *Legionella* species count in water from showers.

2.1 Test description

Water samples were taken from five different clinical wards in the hospital showing that 50% of the water coming from showers in these wards was contaminated with *Legionella* species. In two of the highly contaminated wards Shower Filters were placed and the water was monitored for a 35 day period. Weekly samples were taken both directly from the waterline and from effluent water of the Medical Water Filters. The samples were analysed for *Legionella* species at Vitens Laboratory.

2.2 Test results

The results in Tables 5 and 6 show the influent and effluent values of weekly samples taken from Shower Filters placed at two different wards, coronary and urology respectively. The influent data is of samples taken directly from the water line. The effluent data is of samples collected from the same water line but filtered with Shower Filters.

Table 5: Results from clinical tests at the coronary ward

Week	Shower number	Influent (<i>Legionella</i> CFU/L)	Effluent (<i>Legionella</i> CFU/L)
0	I	8,400	<100
	II	36,000	<100
1	I	20,000	<100
	II	70,500	<100
2	I	13,000	<100
	II	22,500	<100
3	I	42,000	<100
	II	11,000	<100
4	I	8,000	<100
	II	5,300	<100
5	I	15,500	<100
	II	7,700	<100

Table 6: Results of the clinical tests at the urology ward

Week	Shower number	Influent (<i>Legionella</i> CFU/L)	Effluent (<i>Legionella</i> CFU/L)
0	I	100	<100
	II	2,900	<100
1	I	1,600	<100
	II	3,900	<100
2	I	7,300	<100
	II	1,200	<100
3	I	350	<100
	II	6,700	<100
4	I	<100	<100
	II	1,400	<100
5	I	100	<100
	II	600	<100

2.3 Conclusion

Results obtained during weekly tests over 35 days showed that 23 of 24 water samples from showers from several departments contained *Legionella*, while *Legionella* count in all water samples from the Medical Shower Filter were below the detection limit. It was concluded that also in the clinical setting microorganisms are completely retained by Pentair Medical Water Filters.

The Management Summaries of the microbiological tests issued by Vitens Laboratory are added in Appendices, pages 35-44



Chemical Resistance

4.1 Test description

In order to test the chemical resistance of the Medical Water Filters they were exposed to chlorine of 1200 ppm hypochlorite for 10 hrs and compared to blanks of unused filters and filters flushed for 10 hrs with tap water. Samples were evaluated both externally and internally for discolourations and defects, while membranes were evaluated by tensile strength measurements.

4.2 Test results

The Medical Water Filters exposed to 1200 ppm hypochlorite were compared to blanks. No defects or discolourations were found (Fig. 2). Also tensile strength of the membranes was the same for both hypochlorite exposed and unexposed membranes.



Figure 2: Evaluation of Shower Filter for defects and discolourations

4.3 Conclusions

Exposure to 1200 ppm hypochlorite for 10 h does not negatively influence the Medical Water Filters. Therefore, it can be concluded that the Medical Water Filters are compatible with this chemical treatment.

Flow Rate & Pressure Test

5.1 Test description

In order to evaluate the flow rate, both Medical Tap Filters and Medical Shower Filters were flushed with tap water at increasing pressure. Tests on the Medical Shower Filter were performed with and without a 6 L/min flow restrictor, which is recommended for water saving purposes. Tests on the Medical Tap Filter were performed with the compulsory flow restrictor of 4 L/min.

5.2 Test results

Results of the Medical Shower Filter and Medical Tap Filter are shown in Figure 2 and 3 respectively.

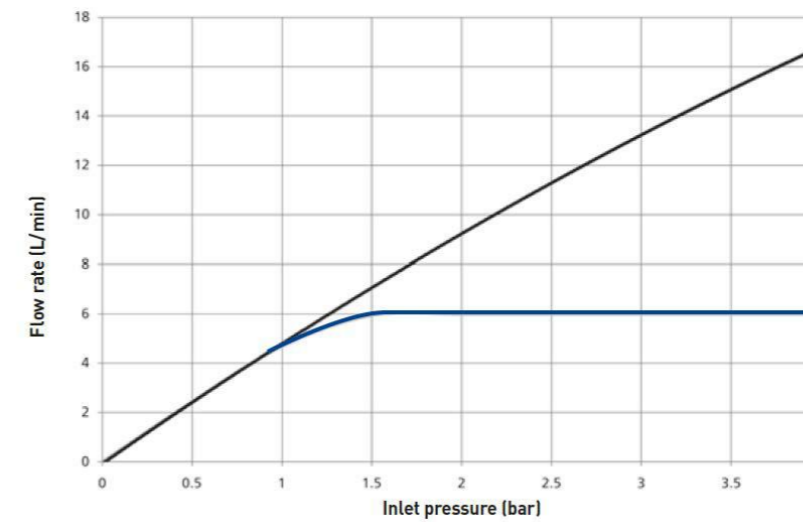

Figure 2: Flow rate-pressure curve of the Medical Shower Filter with (blue) and without (black) a 6 L/min flow restrictor

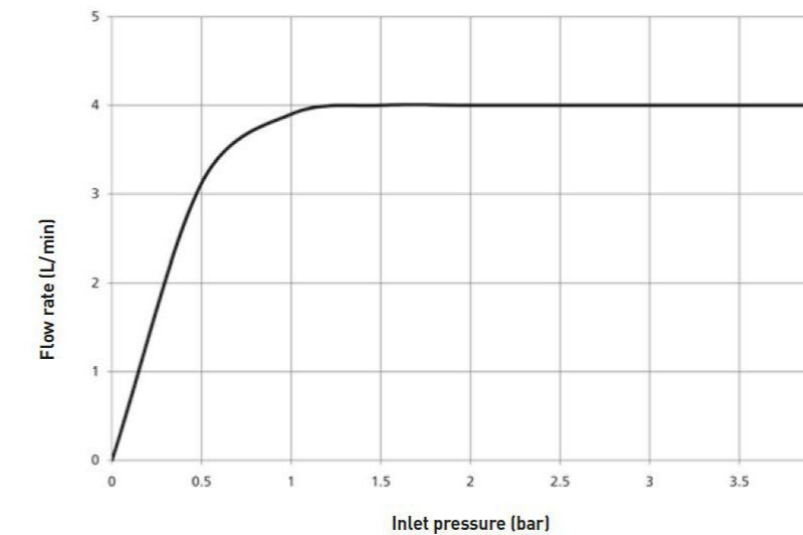

Figure 3: Flow rate-pressure curve of the Medical Tap Filter with a 4 L/min flow restrictor

5.3 Conclusions

The Medical Water Filters show increasing flow rates with increasing pressure, where flow rate is levelled off at the desired level by use of a flow restrictor.



Appendices

- Management Summaries
- Manufacturer's Datasheet
- Certification
- Installation Instructions



Management Summaries

Legionella pneumophila Product Retention Tests

6.1 Management Summary ASTM F838-05 *Pseudomonas Diminuta* Removal



Management Summary

Pseudomonas diminuta removal on Pentair Medical Water Filters

Introduction

Three Pentair Medical Water Filter cartridges, containing Capfil Microfiltration Membranes type MF 02 M12 LE sp, were tested according to ASTM International, Designation: F838-05: "Standard Test Method for Determining Bacterial Retention of Membrane Filters Utilized for Liquid Filtration".

The tests were performed in order to prove that the cartridges can quantitatively retain large numbers of organisms (10^7 organisms per cm^2 of effective filtration area required area required by ASTM F 838-05).

Methods

The testing was performed on three cartridges from October 20th, 2008 onward. The tests were performed with bacteria *Pseudomonas diminuta* (ATCC 19146) as specified in ASTM F838-05. The test set up an protocol were compliant with the ASTM F838-05 standard. The feed and filtrate samples taken from the challenge tests were analyzed by Vitens Laboratory, Leeuwarden, the Netherlands, an ISO 17025 accredited laboratory. As the surface area of the membranes in these filters is around 1000 cm^2 a suitable feed stock of *Pseudomonas diminuta* was made to meet the test's requirements. The analysis of the samples was conducted within 24 hours after the testing. Detection and enumeration of the *Pseudomonas diminuta* was done according to ISO 9308-1.

Test results

Filter	1	2	3	1	2	3
Filter load CFU/L	8×10^9	8×10^9	6×10^9	8×10^9	8×10^9	6×10^9
	After 5 L suspension filtrated			Mixed sample from 5 L		
Effluent CFU/L	<100	<100	<100	<100	<100	<100
Log reduction	>7.2	>7.2	>7.2	>7.2	>7.2	>7.2

Note: The table above presents the results of the *Pseudomonas diminuta* challenge experiments, using data from the analytical report of Vitens. The ASTM standard states a challenge of 10^7 bacteria per cm^2 of effective filtration area (partition 4, page 1). As can be seen from the table all cartridges perform according to the standard.

Conclusion

No *Pseudomonas diminuta* were found in any of the samples resulting in a log retention of >7.2. This proves the Pentair Medical Water Filters perform according to the ASTM F838-05 standard for membrane filters.

6.2 Management Summary *Legionella pneumophila* Product retention tests



Management Summary

Legionella pneumophila removal on Pentair Medical Water Filters

Introduction

Three Pentair Medical Water Filter cartridges, containing Capfil Microfiltration Membranes type MF 02 M12 LE sp, were submitted to a long term microbial challenge test at Vitens Laboratories, Leeuwarden, the Netherlands, an ISO 17025 accredited laboratory. Tests were performed in order to prove that the cartridges have a bacterial retention level of $\geq \log 6$ for the bacteria *Legionella pneumophila* for a period of 11 weeks.

Methods

The test was performed on three cartridges from 2nd July 2009 onward. Tests were performed under test conditions selected to show the long term performance of microbiological water purifiers. First the cartridges were flushed with 50 L filter sterilized water, followed by a challenge of 5 L water with a minimum concentration of 8×10^8 *Legionella pneumophila* (serotype 9) per liter. Effluent samples were taken at the end of the challenge followed by flush with 200 L filter sterilized water. The procedure was repeated 3 times a week for a period of 8 weeks followed by a final sample in week 11. The feed and effluent samples taken from the challenge tests were analyzed by Vitens Laboratories, Leeuwarden, the Netherlands. Analysis of the samples was conducted within 24 hours after the testing. Detection and enumeration of the *Legionella pneumophila* (serotype 9) was done according to NEN 6265:2007.



Management Summary

Test results

The table below displays the results of the *Legionella pneumophila* challenge experiments, using the data from the analytical report of Vitens.

Cartridge	Log retention of <i>Pseudomonas seruginosa</i>		
	1	2	3
Start of test	>6.8	>6.8	>6.8
After 4 days	>7.0	>7.0	>7.0
After 5 days	>7.5	>7.5	>7.5
After 1 week	>7.6	>7.6	>7.6
After 1 week and 4 days	>8.6	>8.6	>8.6
After 1 week and 5 days	>7.5	>7.5	>7.5
After 2 weeks	n.d.	n.d.	n.d.
After 2 weeks and 4 days	>8.5	>8.5	>8.5
After 2 weeks and 5 days	>7.2	>7.2	>7.2
After 3 weeks	>7.1	>7.1	>7.1
After 3 weeks and 4 days	>7.0	>7.0	>7.0
After 3 weeks and 5 days	>6.9	>6.9	>6.9
After 4 weeks	>7.0	>7.0	>7.0
After 4 weeks and 4 days	>7.1	>7.1	>7.1
After 4 weeks and 5 days	>7.1	>7.1	>7.1
After 5 weeks	>7.1	>7.1	>7.1
After 5 weeks and 4 days	>6.9	>6.9	>6.9
After 5 weeks and 5 days	>7.0	>7.0	>7.0
After 6 weeks	>7.1	>7.1	>7.1
After 6 weeks and 4 days	>7.0	>7.0	>7.0
After 6 weeks and 5 days	>6.4	>6.4	>6.4
After 7 weeks	>7.2	>7.2	>7.2
After 7 weeks and 5 days	>7.4	>7.4	>7.4
After 8 weeks	>7.3	>7.3	>7.3
After 11 weeks	>7.1	>7.1	>7.1

Conclusion

The retention results are all above log 6.4, which is more than the required >log 6. Thus it can be concluded that the Pentair Medical Water Filters meet the set retention requirements for *Legionella pneumophila*.



Management Summary

Long term bacterial retention by Norit membranes

Introduction

Norit Filtrix uses Norit's state of the art membranes, which are successfully applied with a lifetime of years in the world's most advanced water purification plants. The maximum replacement interval of Norit Filtrix point of use products is 6 months, while the minimal microbial retention required by international standards like the NSF protocol P231 is log 6.

Used methods

To investigate long term retention, tests were performed during a period of six months using cartridges containing Norit Capfil microfiltration membranes and frequent challenge with a high bacterial load. Furthermore, both the bacteria *Klebsiella terrigena* (ATCC 33257) and *Legionella pneumophila* (serotype 9) were used. Tests were performed under test conditions which are based on NSF protocol P231 for microbiological water purifiers. Cartridges containing the membranes were challenged at least monthly with a minimum concentration of 7×10^8 bacteria per liter after which an effluent samples was taken. The feed and effluent samples taken from the challenge tests were analyzed by Vitens Laboratory, Leeuwarden, The Netherlands. Analysis of the samples was conducted within 24 hours after the challenge. Detection and enumeration of the *Legionella pneumophila* and *Klebsiella terrigena* was done according to NEN 6265:2007 and ISO 9308-1, respectively.

Test results

The table below displays the results of the bacterial challenge experiments, using the data from the analytical reports of Vitens.

Cartridge	Log reduction <i>Klebsiella terrigena</i>			Log reduction <i>Legionella pneumophila</i>		
	1	2	3	1	2	3
After 1 month	>7.5	>6.9	>7.4	>7.2	>7.2	>7.2
After 2 months	>7.5	>7.5	>7.7	>7.2	>7.2	>7.2
After 3 months	>7.6	>7.6	>7.6	>7.1	>7.1	>7.1
After 4 months	>7.8	>7.8	>7.7	>7.2	>7.2	>7.2
After 5 months	>7.7	>7.7	>7.6	>7.5	>7.5	>7.5
After 6 months	>7.7	>7.7	>7.6	>7.2	>7.2	>7.2

Conclusion

The results show a retention performance of log 6.9, which is more than the required log 6 by NSF protocol P231. It can be concluded that over a period of at least 6 months Norit Capfil membranes meet the retention requirements for *Klebsiella terrigena* and *Legionella pneumophila*.

Note: Pentair acquired the part of Norit in 2011 to which Filtrix and X-Flow belonged. Filtrix was merged into the X-Flow range by Pentair.

6.4 Management Summary *Pseudomonas Aeruginosa* retention tests

Management Summary



Pseudomonas aeruginosa removal on Pentair Medical Water Filters

Introduction

Three Pentair Medical Water Filter cartridges, containing Capfil Microfiltration Membranes type MF 02 M12 LE sp, were submitted to a long term microbial challenge test at Vitens Laboratory, Leeuwarden, the Netherlands, an ISO 17025 accredited laboratory. Tests were performed in order to prove that the cartridges are capable to achieve a minimum retention level of $\geq \log 6$ for *Pseudomonas aeruginosa* for a period of 26 weeks.

Methods

Tests were performed on three cartridges from 24th January 2011 under test conditions selected to show the long term performance of microbiological water purifiers. First the cartridges were flushed with 50 L filter sterilized water, followed by a challenge of 5 L water with a minimum concentration of 2×10^8 *Pseudomonas aeruginosa* per liter. Effluent samples were taken at the end of the challenge followed by flush with 200 L filter sterilized water. The procedure was repeated 3 times per week over a period of 8 weeks followed by once a month over a period of 4 months. The feed and effluent samples taken from the challenge tests were analyzed by Vitens Laboratory, Leeuwarden, The Netherlands. Analysis of the samples were conducted within 24 hours after the challenge.

Management Summary



Test results

The table below displays the results of the *Pseudomonas aeruginosa* challenge experiments, using the data from the analytical reports of Vitens Laboratory.

Cartridge	Log retention of <i>Pseudomonas seruginosa</i>		
	1	1	3
Start of test	>6.4	>6.4	>6.4
After 1 day	>6.4	>6.4	>6.4
After 3 days	>6.4	>6.4	>6.4
After 1 week	>6.9	>6.9	>6.9
After 1 week and 1 day	>7.3	>7.3	>7.3
After 1 week and 3 days	>6.9	>6.9	>6.9
After 2 weeks	>6.0	>6.0	>6.0
After 2 weeks and 1 day	>7.4	>7.4	>7.4
After 2 weeks and 3 days	>7.0	>7.0	>7.0
After 3 weeks	>6.8	>6.8	>6.8
After 3 weeks and 1 day	>7.3	>7.3	>7.3
After 3 weeks and 3 days	>7.1	>7.1	>7.1
After 4 weeks	>6.8	>6.8	>6.8
After 4 weeks and 1 day	>6.8	>6.8	>6.8
After 4 weeks and 3 days	>6.7	>6.7	>6.7
After 5 weeks	>8.1	>8.1	>8.1
After 5 weeks and 1 day	>8.1	>8.1	>8.1
After 5 weeks and 3 days	>7.8	>7.8	>7.8
After 6 weeks	>6.1	>6.1	>6.1
After 6 weeks and 1 day	>6.1	>6.1	>6.1
After 6 weeks and 3 days	>6.3	>6.3	>6.3
After 7 weeks	>6.7	>6.7	>6.7
After 7 weeks and 1 day	>6.2	>6.2	>6.2
After 7 weeks and 3 days	>7.0	>7.0	>7.0
After 3 months	>7.3	>7.3	>7.3
After 4 months	>7.2	>7.2	>7.2
After 5 months	>5.7	>5.7	>5.7
After 6 months	>7.7	>7.7	>7.7

Conclusion

Almost all samples show a retention performance above the goal of log 6. In one case the influent target level of log 6 wasn't reached due to low influent concentration. In all cases no *Pseudomonas aeruginosa* passed the membrane. It can be concluded that over a period of at least 26 weeks Pentair Medical Water Filters meet the retention requirements for *Pseudomonas aeruginosa*.

6.5 Management Summary *Fusarium solani* retention tests

Management Summary



Fusarium solani removal on Pentair Medical Water Filters

Introduction

Three Pentair Medical Water Filter cartridges, containing Capfil Microfiltration Membranes type MF 02 M12 LE sp, were submitted to a long term microbial challenge test at Vitens Laboratory, Leeuwarden, the Netherlands, an ISO 17025 accredited laboratory. Tests were performed in order to prove that the cartridges are capable to achieve a minimum retention level of $\geq \log 4$ for *Fusarium solani* for a period of 26 weeks.

Methods

Tests were performed on three cartridges from 01st November 2010 under test conditions selected to show the long term performance of microbiological water purifiers. Due to the larger size of fungi a minimum reduction level of log 4 was required in order to determine the capability of fungi reduction.

First the cartridges were flushed with 50 L filter sterilized water, followed by a challenge of 5 L water with a minimum concentration of 2×10^5 *Fusarium solani* per liter. Effluent samples were taken at the end of the challenge followed by flush with 200 L filter sterilized water. The procedure was repeated 3 times per week over a period of 8 weeks followed by once a month over a period of 4 months. The feed and effluent samples taken from the challenge tests were analyzed by Vitens Laboratory, Leeuwarden, The Netherlands. Analysis of the samples were conducted within 24 hours after the challenge.

Management Summary



Test results

The table below displays the results of the *Fusarium solani* challenge experiments, using the data from the analytical reports of Vitens Laboratory.

Cartridge	Log retention of <i>Pseudomonas seruginosa</i>		
	1	1	3
Start of test	>3.9	>3.9	>3.9
After 1 day	>3.7	>3.7	>3.7
After 3 days	>3.7	>3.7	>3.7
After 1 week	>4.0	>4.0	>4.0
After 1 week and 1 day	>4.1	>4.1	>4.1
After 1 week and 3 days	>4.0	>4.0	>4.0
After 2 weeks	>4.2	>4.2	>4.2
After 2 weeks and 1 day	>4.0	>4.0	>4.0
After 2 weeks and 3 days	>4.2	>4.2	>4.2
After 3 weeks	>4.0	>4.0	>4.0
After 3 weeks and 1 day	>4.2	>4.2	>4.2
After 3 weeks and 3 days	>4.2	>4.2	>4.2
After 4 weeks	>4.2	>4.2	>4.2
After 4 weeks and 1 day	>4.2	>4.2	>4.2
After 4 weeks and 3 days	>4.3	>4.3	>4.3
After 5 weeks	>4.3	>4.3	>4.3
After 5 weeks and 1 day	>4.4	>4.4	>4.4
After 5 weeks and 3 days	>3.7	>3.7	>3.7
After 6 weeks	>4.1	>4.1	>4.1
After 6 weeks and 1 day	>4.1	>4.1	>4.1
After 6 weeks and 3 days	>4.2	>4.2	>4.2
After 7 weeks	>3.7	>3.7	>3.7
After 7 weeks and 1 day	>4.1	>4.1	>4.1
After 7 weeks and 3 days	>3.8	>3.8	>3.8
After 3 months	>4.1	>4.1	>4.1
After 4 months	>4.2	>4.2	>4.2
After 5 months	>4.3	>4.3	>4.3
After 6 months	>4.4	>4.4	>4.4

Conclusion

Almost all samples show a retention performance above the goal of log 4. In some cases the influent target level of log 4 wasn't reached due to low influent concentration. In all cases no *Fusarium solani* passed the membrane. It can be concluded that over a period of at least 26 weeks Pentair Medical Water Filters meet the retention requirements for *Fusarium solani*.

6.6 Management Summary on Clinical Evaluation

Management Summary



Clinical evaluation of Pentair Medical Water Filters

Introduction

During a routine check on 18 June 2009 a contamination with *Legionella* species was detected in the effluent of several showers in the Medical Spectrum Twente hospital, location Ariënsplein, the Netherlands. After this detection all showers were replaced by Pentair Medical Water Filters. This situation was considered suitable for a clinical evaluation of these Water Filters.

Methods

For this clinical evaluation five clinical wards equipped with the Pentair Medical Water Filters were chosen for further analysis. At each ward the effluent of two showers was analyzed for the presence of *Legionella* species one week after placement.

Furthermore, at two wards two showers were weekly evaluated for a period of five weeks, the recommended replacement interval of the product. All samples were collected and analyzed for the presence of *Legionella* species by culture according to NEN 6265:2007, by Vitens Laboratory, Leeuwarden, the Netherlands, an ISO 17025 accredited laboratory. The detection level of *Legionella* with the applied method was 100 cfu/ L. Influent samples were taken from the piping at the point where a shower is attached. Effluent samples were taken from the Pentair Medical Water Filters placed. Analysis of all samples was done within 24 hours.

Results

Results for 5 clinical wards after 1 week of use are shown in the table below.

Ward	Shower number	Influent (<i>Legionella</i> cfu/L)	Effluent (<i>Legionella</i> cfu/L)
Coronary	I	8.600	<100
	II	8.700	<100
Urology	I	1.600	<100
	II	<100	<100
Oncology	I	9.500	<100
	II	4.900	<100
Infectious disease	I	<100	<100
	II	<100	<100
Elderly nursing	I	<100	<100
	II	<100	<100

Management Summary



Results during 5 weeks of use are shown in the table below.

Ward	Week	Shower number	Influent (<i>Legionella</i> cfu/L)	Effluent (<i>Legionella</i> cfu/L)
Coronary	0	I	8.400	<100
		II	36.000	<100
	1	I	20.000	<100
		II	35.500	<100
	2	I	13.000	<100
		II	22.500	<100
	3	I	42.000	<100
		II	11.000	<100
	4	I	8.000	<100
		II	5.300	<100
5	I	15.500	<100	
	II	7.700	<100	
Urology	0	I	100	<100
		II	2.900	<100
	1	I	1.600	<100
		II	3.900	<100
	2	I	7.300	<100
		II	1.200	<100
	3	I	350	<100
		II	6.700	<100
	4	I	<100	<100
		II	1.400	<100
5	I	100	<100	
	II	600	<100	

Conclusion

Fifty percent of the influent samples of the 5 wards were contaminated with *Legionella* species, while in the effluent samples no *Legionella* species were detected after 1 week usage. Furthermore, at two wards for a five week period 95% of influent samples were contaminated while again no *Legionella* species were detected in the effluent samples taken from the Pentair Medical Water Filters. Effective *Legionella* species retention by the Pentair Medical Water Filters was shown in this clinical study.



MEDICAL WATER FILTERS STERILIZED SERIES SL92

Patient and staff safety in hospitals is of vital importance. Especially in high-risk areas such as critical wards, intensive care units and operating theaters, where sterile-grade water is needed.



One of the main concerns is the risk of bacterial infections which can be caused by microbiologically contaminated shower and tap water. Waterborne pathogens can accumulate in biofilm located within the plumbing system, even if a hospital disinfects water at the point-of-entry. The pathogens can then be transmitted to patients when the water is used for their care. Pentair, a specialist in water purification solutions, offers a complete range of point-of-use membrane filters for shower heads and taps/faucets. These are specifically designed for use in healthcare facilities.

BENEFITS

- Protects from waterborne bacteria like legionella
- For high risk areas like such as critical wards, intensive care units and operating theatres
- Relief in outbreak situations or permanent infection control
- Sterilized by gamma irradiation (>25Kgy - the standard for medical products)

APPLICATIONS

Pentair Medical Filters sterilized version offers protection in high-risk (sterile) areas where there is risk of waterborne infection. It provides reliable and easy protection at the last possible moment before patient and staff contact.

MATERIALS AND OPERATING SPECIFICATIONS

- Filter Media**
Capillary microfiltration membranes
- Micron Rating**
0,2 µm
- Max. operating pressure**
5 bar (72,5 psi)
- Operating temperature**
Continually 0 - 60 °C @ 5 bar inlet pressure 70 °C for 60 min. cumulative over the lifetime of the filter cartridge (compliant with thermal disinfection procedures)
- Chlorine exposure**
1.200 ppm for 10 hours cumulative over the lifetime of the filter cartridge
- Storage & Handling**
- Validated shelf life: 2 years
 - Keep dry during storage
 - Store between 0 and 50 °C
 - Disposable product; discard as regular waste

X-FLOW

DATASHEET MEDICAL WATER FILTERS

FILTER CARTRIDGE SPECIFICATIONS & PERFORMANCE DATA

MODEL NUMBER	MSF-SLSS	MSF-SLRC	MTFW-SLSS	MTFW-SLRC	MTFD-SLSS	MTFD-SLRC
Model name	Medical Shower Filter Startset	Medical Shower Filter Replacement Cartridge	Medical Tap Filter Washing S Startset	Medical Tap Filter Washing Replacement Cartridge	Medical Tap Filter Drinking Startset	Medical Tap Filter Drinking Replacement Cartridge
Max. Dimensions	136 x 63 mm	88 x 63 mm	136 x 63 mm	88 x 63 mm	136 x 63 mm	88 x 81 mm
Weight	240 g	150 g	240 g	150 g	240 g	150 g
Connection	1/2 inch BSP/NPT	proprietary quick release	22 mm inner thread ⁽¹⁾	proprietary quick release	22 mm inner thread ⁽¹⁾	proprietary quick release
Initial Flowrate @ 2 bar	8 l/min (2.4 Gpm) ⁽²⁾	8 l/min (2.4 Gpm) ⁽²⁾	6 l/min (1.5 Gpm) ⁽²⁾	6 l/min (1.5 Gpm) ⁽²⁾	6 l/min (1.5 Gpm) ⁽²⁾	6 l/min (1.5 Gpm) ⁽²⁾
Validated Lifetime	92 days (3 months)					
Biological Retention⁽⁴⁾	Bacteria > log 7 / Fungi > log 4					

⁽¹⁾ adapter to 24 mm, 1/2" outer & inner thread available ⁽²⁾ flow restrictor recommended ⁽³⁾ flow restrictor obliged ⁽⁴⁾ Refer to the validation guide for information

Product Certification: The Medical Water Filters Standard series comply to the material safety requirements of KIWA, KTW and WRAS. Please refer to our validation guide for more information on biological retention tests.

SHOWERFILTER

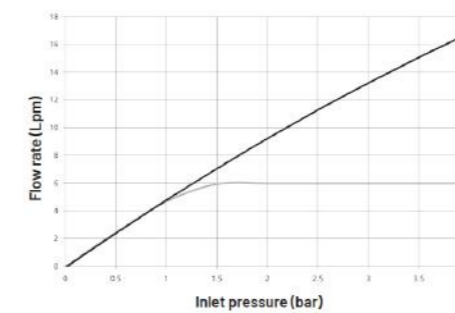

TAPFILTER

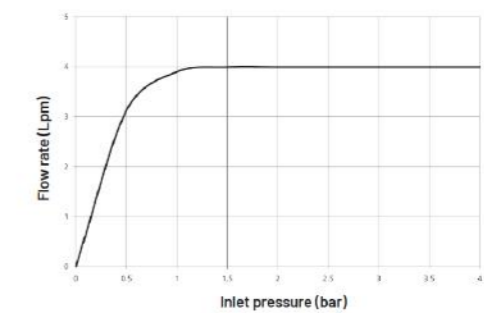

Pentair Medical Water Filters are worldwide exclusively distributed by Fealter BV The Netherlands. For more information please visit our website fealter.com



X-FLOW BV | P.O. Box 739 | NL-7500 AS Enschede | Netherlands | xflow.pentair.com

All Pentair trademarks and logos are owned by Pentair. All other brand or product names are trademarks or registered marks of their respective owners. Because we are continuously improving our products and services, Pentair reserves the right to change specifications without prior notice. Pentair is an equal opportunity employer.
DS MWFS192 EN 2719 © 2019 Pentair. All Rights Reserved.



Certification

The Water Regulations Approval Scheme (WRAS) is an independent UK certification body for products and materials, helping business and consumers choose compliant products that keep water safe.

The Medical Shower and Tap Filters have passed the required BS6920 material testing and subsequent mechanical product testing to demonstrate that they are of a suitable quality to filter water intended for public supply.



Pentair Declaration of Conformity

Medical Tap Filter 1411069

The EU Declaration of Conformity is a document required by the manufacturer to state that the product specified satisfies the essential requirements of the applicable legislation. By providing a signed EU Declaration of Conformity, the manufacturer assumes responsibility for the compliance of the product.

	Declaration of Conformity	Doc ref : DoC X-Flow MWF Is-01-15-EN.docx
		Page: 1 of 2

Declaration of Conformity

Product Identification	
Product group name	Model Numbers
Medical Water Filters (Sterile Class)	MSF SCxx; MSF HCxx; MTFx SCxx

Manufacturer		
Name of Company	Address	Representative
X-Flow (a subsidiary of Pentair Inc.)	Marssteden 50 7574 TC ENSCHEDE	Mr. Frank van Heusden

Registration Information		
Notified Body ID#	CE Certificate Number	Date CE Marking first applied
DEKRA Certification B.V. 0344	2146741CE01	7 th September 2012

Device Classification	Route to Compliance
Class Is (sterile)	MDD 93/42/EEC, Annex V In combination with Annex VII As amended: 2007/47/EC

X-Flow BV declares that the above mentioned products meet the provision of the Council Directive 93/42/EEC for Medical Devices. All supporting documentation is retained at the premises of the manufacturer.

This Declaration of Conformity covers the Medical Water Filters as specified in the product list belonging to this declaration, and is valid for all products concerned bearing the CE marking and manufactured at the following site(s):

MANUFACTURING SITE: Marssteden 50, 7574TC Enschede, NL

COMPANY REPRESENTATIVE: Frank van Heusden

TITLE: Senior Product Manager **SIGNATURE:** 

DATE: 1st January 2015

	Declaration of Conformity	Doc ref : DoC X-Flow MWF Is-01-15-EN.docx
		Page: 2 of 2

Appendix

Date: 01-01-2015

Product list

Medical Water Filters

This product list belongs to the Declaration of Conformity identified by DoC X-Flow MWF Is-01-15-EN.docx and specifies the CE marked products concerned that X-Flow BV intends to distribute in conformity with the provisions of the Council Directive 93/42/EEC of 14 June 1993 concerning medical devices.

Device Name	Type/Model/Ref	Risk Class / rule	Date of first Batch/Lot
Medical ShowerFilter Sterile Class Start set	MSF-SCSS	Class Is / rule 1	09-2012
Medical ShowerFilter Sterile Class Replacement Cartridge	MSF-SCRC	Class Is / rule 1	09-2012
Medical ShowerFilter HomeCare Start set	MSF-HCSS	Class Is / rule 1	09-2013
Medical TapFilter Washing Sterile Class Start set	MTF-WSCSS	Class Is / rule 1	09-2012
Medical TapFilter Washing Sterile Class Replacement Cartridge	MTF-WSCRC	Class Is / rule 1	09-2012
Medical TapFilter Drinking Sterile Class Start set	MTF-DSCSS	Class Is / rule 1	09-2012
Medical TapFilter Drinking Sterile Class Replacement Cartridge	MTF-DSCRC	Class Is / rule 1	09-2012

Installation Instructions

Important Precautions and Instructions

The product is suitable only for connection to a cold-water or mixing-water facility. The maximum allowable operating temperature is 60°C (122°F). The maximum allowable operating pressure of the filter system is 5 bar (72.5 psi). Contact your water supplier or your technical department for information about the current water pressure.

Make sure that the filter system is connected correctly by carefully following these operating instructions. Do not use if the package has been damaged, or after the expiry date has passed. We recommend washing your hands thoroughly before installation. Avoid contact with the outlet opening of the filter as much as possible to prevent bacterial contamination. During periodic disinfection of the water supply system, the filter does not have to be removed. Depending on the disinfection method used, the filter may have to be replaced afterwards. Please refer to the filter data sheet for this. Avoid exposure to temperatures below 0°C after first use. Handle with care, do not expose to shocks; this may damage the filter material. When in doubt, we recommend replacing with a new filter cartridge.

Installation of the Shower Filter

- 1 Where required, remove the existing shower head.
- 2 Remove the Shower Filter from the packaging.
- 3 Attach the filter head to the handle.
- 4 Place the Shower Filter on the end of the shower hose. The Shower Filter comes standard with a ½" BSP male coupling. Make sure that the flat seal of the shower hose coupling is in the correct position.
- 5 Attach the watertight 2-part date label supplied, to the filter and write down the date of first use and the replacement date on both labels. The top label is for your own administration.
- 6 The Shower Filter can now be put into use.

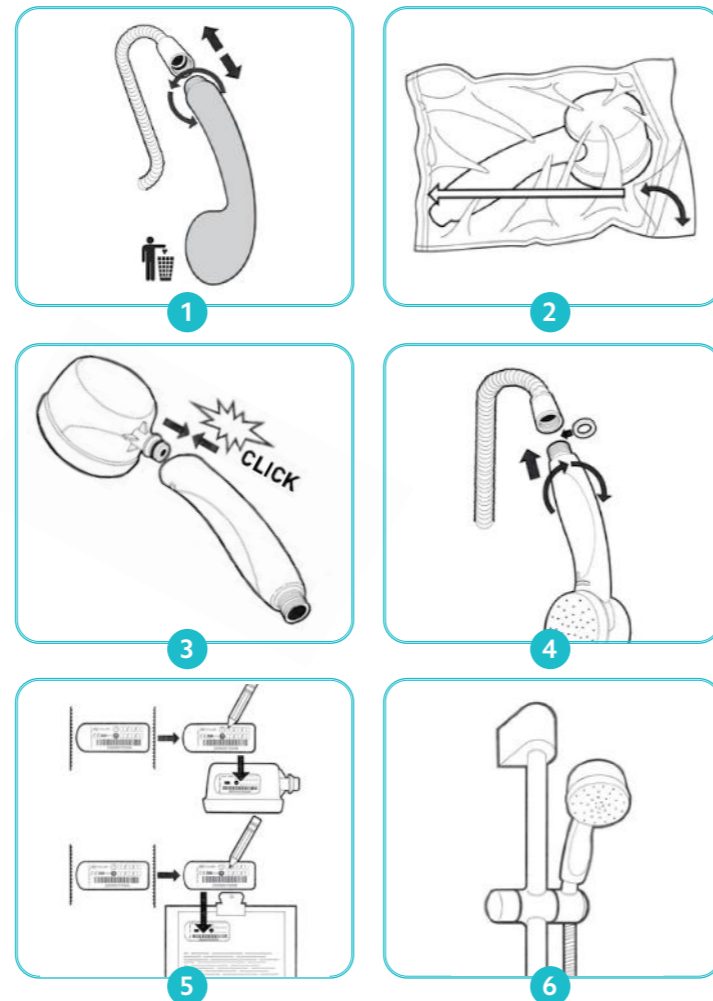

Installation of the Tap Filter

- 1 Where required, remove the outlet piece of the tap.
- 2 Remove the Tap Filter from the packaging.
- 3 Fit the flow regulator (sold separately as item no. MTF-FR) in the designated opening. The arrow on the regulator indicates the flow direction. Press the regulator into place, and then fit the flat gasket.
- 4 Screw the Tap Filter onto the tap opening. The Tap Filter comes standard with a 22mm coupling (inner thread). Adaptors for other sizes are available. Make sure that the flat seal of the coupling is in the correct position. Click the Tap Filter into position.
- 5 Attach the watertight 2-part date label supplied, to the filter and write down the date of first use and the replacement date on both labels. The top label is for your own administration.
- 6 Attach the bottom label to the filter. If you have instrument management software the filter can be registered via the bar code.

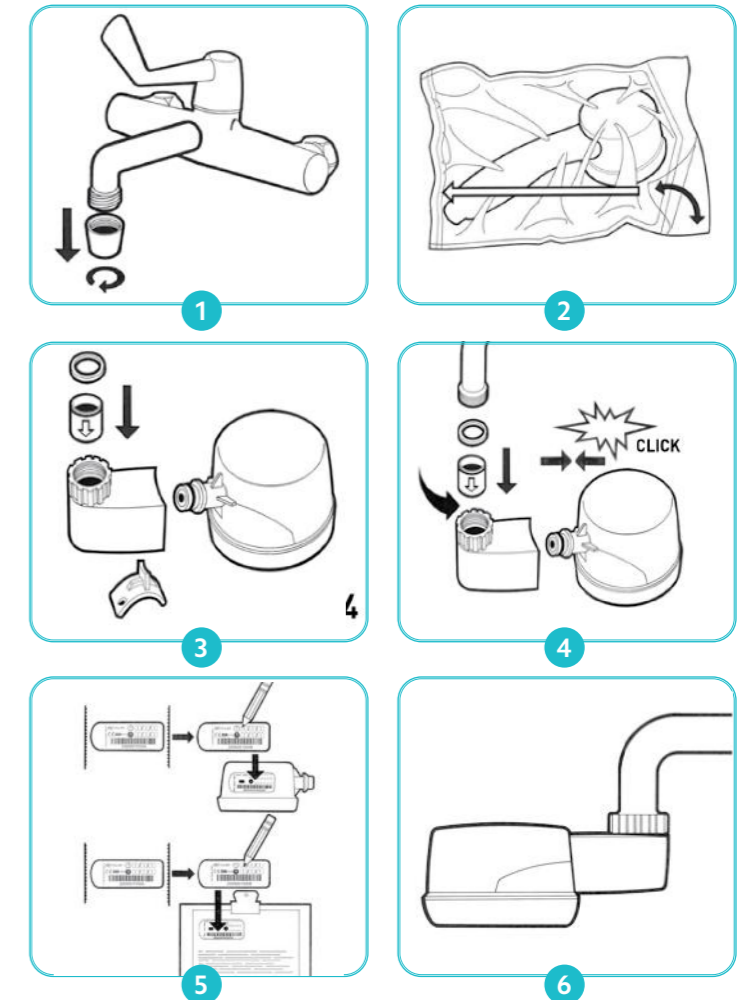

The Tap Filter can now be put into use.

Replacing the Filter Cartridge

The filter must be replaced no later than 92 days after it was used for the first time. Replace the cartridge in any case if the water pressure is noticeably reduced. If the filter needs to be replaced early, this is generally not a result of a defect in the filter system, but rather an indication that the quality of the incoming water is inferior or that this tap is being used more than average.

Follow steps 1-3 to replace the cartridge.

- 1 Remove the filter cartridge from the packaging.
- 2 Remove the used cartridge from the coupling using the grey tool supplied. The non-return valve ensures that no contaminated water can flow out of the cartridge. A small amount of mains water may flow out of the coupling. The used cartridge is sealed and can be disposed of as regular waste. Then place the new cartridge into position by pushing it onto the quick-connect coupling until you hear a click and the cartridge is firmly connected.
- 3 Attach the watertight 2-part date label supplied, to the filter and write down the date of first use and the replacement dates on both labels. The top label is for your own administration. Then attach the bottom label to the filter. If you have instrument management software the filter can be registered via the bar code.

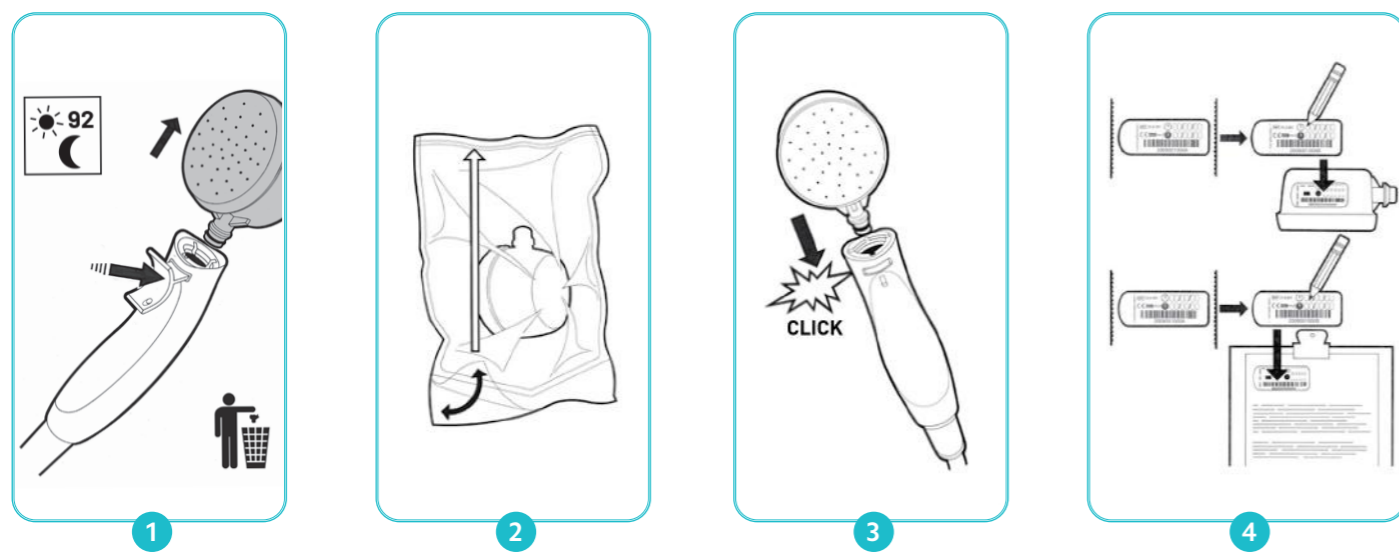







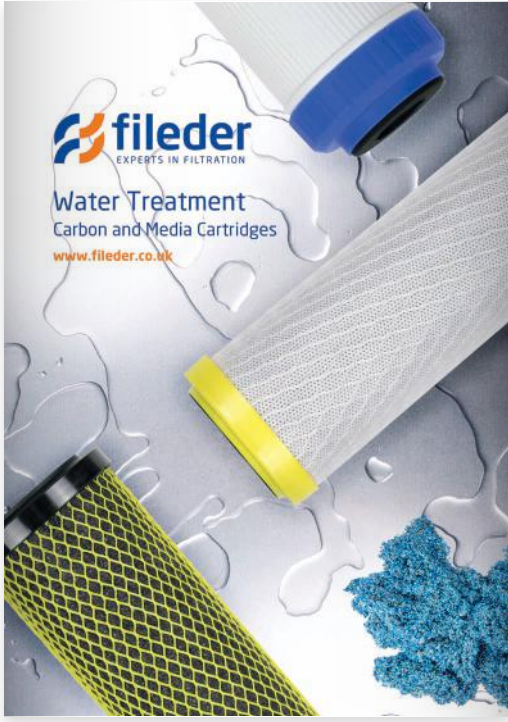





fileder
EXPERTS IN FILTRATION

For T&C's, Terms of Use and Copyright, please visit www.fileder.co.uk

Product Brochures



	Pleated Filtration
	Depth Filtration
	Stainless Steel Cartridges
	High Flow Filtration
	Water Treatment - Carbon & Media Cartridges
	Filter Housings
	Bag Filtration
	Pure Water Membranes
	Pressure Vessels & Media
	Water Softening & Conditioning
	UV Systems
	Food Service
	Filtration & Water Treatment Rental
	Installation & Servicing

Application Brochures



	Solutions for Surface Finishing
	Solutions for Hospitals
	Solutions for Beverage Production
	Solutions for the Coatings Industry
	Solutions for Bacteria and Parasites
	Solutions for Cosmetics and Toiletries
	Filtration for Municipal Water with DWI
	Solutions for Cryptosporidium Protection
	Solutions for Chemical Production

Contact us

Filerder Filter Systems Ltd
 20/20 Business Park
 Maidstone, Kent
 ME16 0LS

Phone: 01622 691886
Fax: 01622 621932
Email: info@filerder.co.uk
Website: www.filerder.co.uk

